

REX-S100, REX-S400, REX-S900 INSTRUCTION MANUAL

IMSRE01-E6

Thank you for purchasing this RKC product. In order to achieve maximum performance and ensure proper operation of your new instrument, carefully read all the instructions in this manual. Please place the manual in a convenient location for easy reference.

SYMBOLS

WARNING : This mark indicates precautions that must be taken if there is danger of electric shock, fire, etc., which could result in loss of life or injury.

CAUTION : This mark indicates that if these precautions and operating procedures are not taken, damage to the instrument may result.



: This mark indicates that all precautions should be taken for safe usage.



: This mark indicates supplemental information on installation, handling and operating procedures.



WARNING

- An external protection device must be installed if failure of this instrument could result in damage to the instrument, equipment or injury to personnel.
- All wiring must be completed before power is turned on to prevent electric shock, fire or damage to instrument and equipment.
- This instrument must be used in accordance with the specifications to prevent fire or damage to instrument and equipment.
- This instrument is not intended for use in locations subject to flammable or explosive gases.
- Do not touch high-voltage connections such as power supply terminals, etc. to avoid electric shock.
- RKC is not responsible if this instrument is repaired, modified or disassembled by other than factory-approved personnel. Malfunction can occur and warranty is void under these conditions.

CAUTION

- This product is intended for use with industrial machines, test and measuring equipment. (It is not designed for use with medical equipment and nuclear energy.)
- This is a Class A instrument. In a domestic environment, this instrument may cause radio interference, in which case the user may be required to take additional measures.
- This instrument is protected from electric shock by reinforced insulation. Provide reinforced insulation between the wire for the input signal and the wires for instrument power supply, source of power and loads.
- Be sure to provide an appropriate surge control circuit respectively for the following:
 - If input/output or signal lines within the building are longer than 30 meters.
 - If input/output or signal lines leave the building, regardless the length.
- This instrument is designed for installation in an enclosed instrumentation panel. All high-voltage connections such as power supply terminals must be enclosed in the instrumentation panel to avoid electric shock by operating personnel.
- All precautions described in this manual should be taken to avoid damage to the instrument or equipment.
- All wiring must be in accordance with local codes and regulations.
- All wiring must be completed before power is turned on to prevent electric shock, instrument failure, or incorrect action. The power must be turned off before repairing work for input break and output failure including replacement of sensor, contactor or SSR, and all wiring must be completed before power is turned on again.

- To prevent instrument damage or failure, protect the power line and the input/output lines from high currents with a protection device such as fuse, circuit breaker, etc.
- Prevent metal fragments or lead wire scraps from falling inside instrument case to avoid electric shock, fire or malfunction.
- Tighten each terminal screw to the specified torque found in the manual to avoid electric shock, fire or malfunction.
- For proper operation of this instrument, provide adequate ventilation for heat dispensation.
- Do not connect wires to unused terminals as this will interfere with proper operation of the instrument.
- Turn off the power supply before cleaning the instrument.
- Do not use a volatile solvent such as paint thinner to clean the instrument. Deformation or discoloration will occur. Use a soft, dry cloth to remove stains from the instrument.
- To avoid damage to instrument display, do not rub with an abrasive material or push front panel with a hard object.
- When high alarm with hold action is used for Alarm function, alarm does not turn on while hold action is in operation. Take measures to prevent overheating which may occur if the control device fails.

NOTICE

- This manual assumes that the reader has a fundamental knowledge of the principles of electricity and process control.
- The figures, diagrams and numeric values used in this manual are only for purpose of illustration.
- RKC is not responsible for any damage or injury that is caused as a result of using this instrument, instrument failure or indirect damage.
- RKC is not responsible for any damage and/or injury resulting from the use of instruments made by imitating this instrument.
- Periodic maintenance is required for safe and proper operation of this instrument. Some components have a limited service life, or characteristics that change over time.
- Every effort has been made to ensure accuracy of all information contained herein. RKC makes no warranty expressed or implied, with respect to the accuracy of the information. The information in this manual is subject to change without prior notice.
- No portion of this document may be reprinted, modified, copied, transmitted, digitized, stored, processed or retrieved through any mechanical, electronic, optical or other means without prior written approval from RKC.

1. PRODUCT CHECK

Check the model code from the following list to determine if the product delivered is as desired.

REX-S100
REX-S400 F □ □ - □ * □ □
REX-S900 ① ② ③ ④ ⑤ ⑥

How to specify safety standard
 When you specify the models with CE mark: UL/CSA certification, please add the suffix of "ICE" to model code.

- ① Control actionF: PID action with AT[Reverse action]
 - ② Input type, ③ Range codeRefer to "Input range table."
 - ④ Control output.....M: Relay contact V: Voltage pulse
 - ⑤ First alarm [ALM1], ⑥ Second alarm [ALM2]
- | | |
|-------------------------------|--------------------------------|
| N: No alarm | H: Process high alarm |
| A: Deviation high alarm | J: Process low alarm |
| B: Deviation low alarm | K: Process high alarm * |
| C: Deviation high/low alarm | L: Process low alarm * |
| D: Band alarm | P: Heater break alarm (CTL-6) |
| E: Deviation high alarm * | S: Heater break alarm (CTL-12) |
| F: Deviation low alarm * | R: Control loop control alarm |
| G: Deviation high/low alarm * | * with hold action |

Input range table

Input type & range	Code
K	0 to 999 °C K21
	0 to 999 °F KB1
J	0 to 999 °C J13
	0 to 999 °F JA8
L	0 to 900 °C L05
	0 to 999 °F LA4
E	0 to 999 °C E05
	0 to 999 °F EA4
N	0 to 999 °C N03
	0 to 999 °F MA3

Input type & range	Code
T	-199 to +400 °C T11
	-199 to +752 °F TB2
U	-199 to +600 °C U07
	-199 to +999 °F UA7
Pt	-199 to +649 °C D19
	-199 to +999 °F DB6
100	-199 to +649 °C P19
	-199 to +999 °F PB5

Accessories

- Mounting brackets 2
- INSTRUCTION MANUAL [IMSRE01-E6]..... 1

2. MOUNTING



WARNING

To prevent electric shock or instrument failure, always turn off the power before mounting or removing the instrument.

■ Cautions for Mounting

- (1) This instrument is intended to be used under the following environmental conditions. **(IEC61010-1)**
[OVERVOLTAGE CATEGORY II, POLLUTION DEGREE 2]
- (2) Use this instrument within the following environment conditions:
 - Allowable ambient temperature: 0 to 50 °C (32 to 122 °F)
 - Allowable ambient humidity: 45 to 85 % RH
 - Installation environment conditions:
Indoor use, Altitude up to 2000 m
- (3) Avoid the following conditions when selecting the mounting location:
 - Rapid changes in ambient temperature which may cause condensation.
 - Corrosive or inflammable gases.
 - Direct vibration or shock to the mainframe.
 - Water, oil, chemicals, vapor or steam splashes.
 - Excessive dust, salt or iron particles.
 - Excessive induction noise, static electricity, magnetic fields or noise.
 - Direct air flow from an air conditioner.
 - Exposure to direct sunlight.
 - Excessive heat accumulation.

■ Dimensions

<REX-S100>

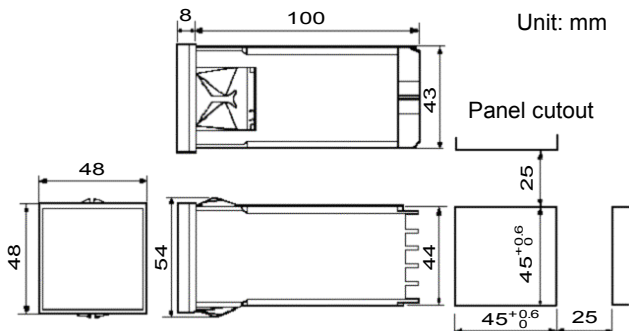

Thickness of panel board: 1 to 5 mm or 5 to 9 mm

<REX-S400>

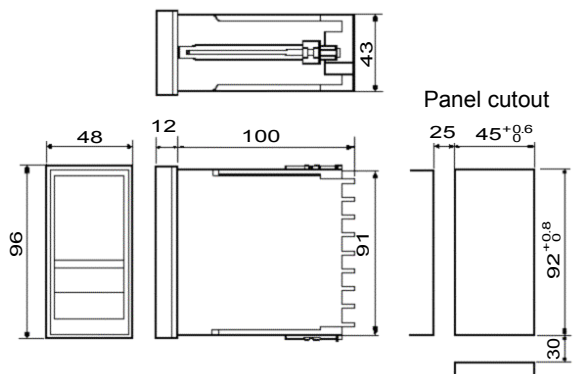

<REX-S900>

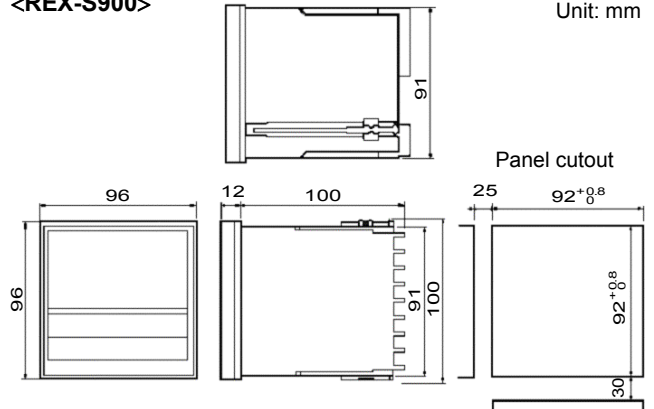

■ Mounting procedures

<REX-S100>

• When the controllers are mounted on panel with 1 to 5 mm in thickness

1. Make a rectangular cutout corresponding to the number of controllers to be mounted on panel by referring to the panel cutout dimensions.
2. Since the mounting brackets are already installed on the controller, insert the controller into the panel from the panel front without removal of the brackets.

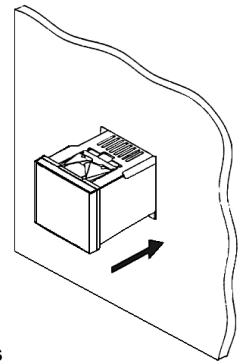

• When the controllers are mounted on panel with 5 to 9 mm in thickness

1. Remove the mounting brackets from the controller with a slotted screwdriver.
2. Engage each mounting bracket with holes marked with "5-9" on the housing and then insert the controller into the panel from the panel front.

<REX-S400/REX-S900>

1. Make a rectangular cutout corresponding to the number of controllers to be mounted on panel by referring to the panel cutout dimensions.
2. Insert the controllers into the panel from the panel front.
3. Insert an upper mounting bracket along the bracket insertion groove from the back, and then engage a projection at the bracket end with a recess at the groove front and also insert metal fitting legs into slots.
4. Tighten a bracket setscrew from the rear of the bracket with Phillips screwdriver.
5. Set the other mounting bracket in the same way as in 3 and 4.

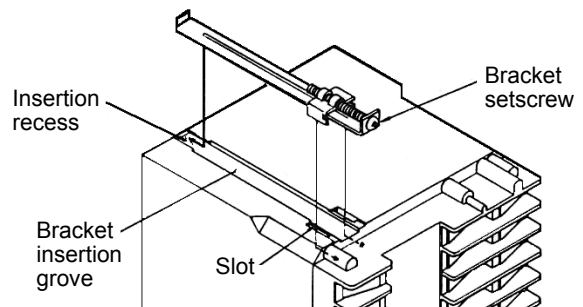

REX-S900 is used in the above figures for explanation, but the same mounting procedures also apply to REX-S400.

3. WIRING



WARNING

To prevent electric shock or instrument failure, do not turn on the power until all wiring is completed. Make sure that the wiring is correct before applying power to the instrument.

■ Cautions for wiring

- For thermocouple input, use the appropriate compensation wire.
- For RTD input, use low resistance lead wire with no difference in resistance between the three lead wires.
- To avoid noise induction, keep input signal wire away from instrument power line, load lines and power lines of other electric equipment.
- If there is electrical noise in the vicinity of the instrument that could affect operation, use a noise filter.
 - Shorten the distance between the twisted power supply wire pitches to achieve the most effective noise reduction.
 - Always install the noise filter on a grounded panel. Minimize the wiring distance between the noise filter output and the instrument power supply terminals to achieve the most effective noise reduction.
 - Do not connect fuses or switches to the noise filter output wiring as this will reduce the effectiveness of the noise filter.
- All wiring must be in accordance with local codes and regulations.
- Allow approximately 5 to 6 seconds for contact output when the instrument is turned on. Use a delay relay when the output line is used for an external interlock circuit.
- This instrument is not furnished with a power supply switch or fuses. If a fuse or power supply switch is required, install close to the instrument.
 - Fuse type: Time-lag fuse
 - Recommended fuse rating: Rated voltage 250 V Rated current: 1 A
- Power supply wiring must be twisted and have a low voltage drop.
- For an instrument with 24 V power supply, supply power from a SELV circuit.
- Make sure that the any wiring such as solderless terminal is not in contact with the adjoining terminals.

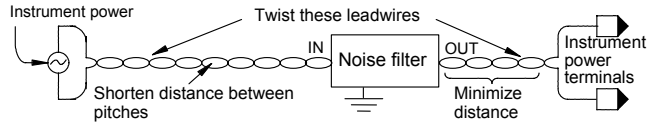

■ Terminals configuration

<REX-S100>

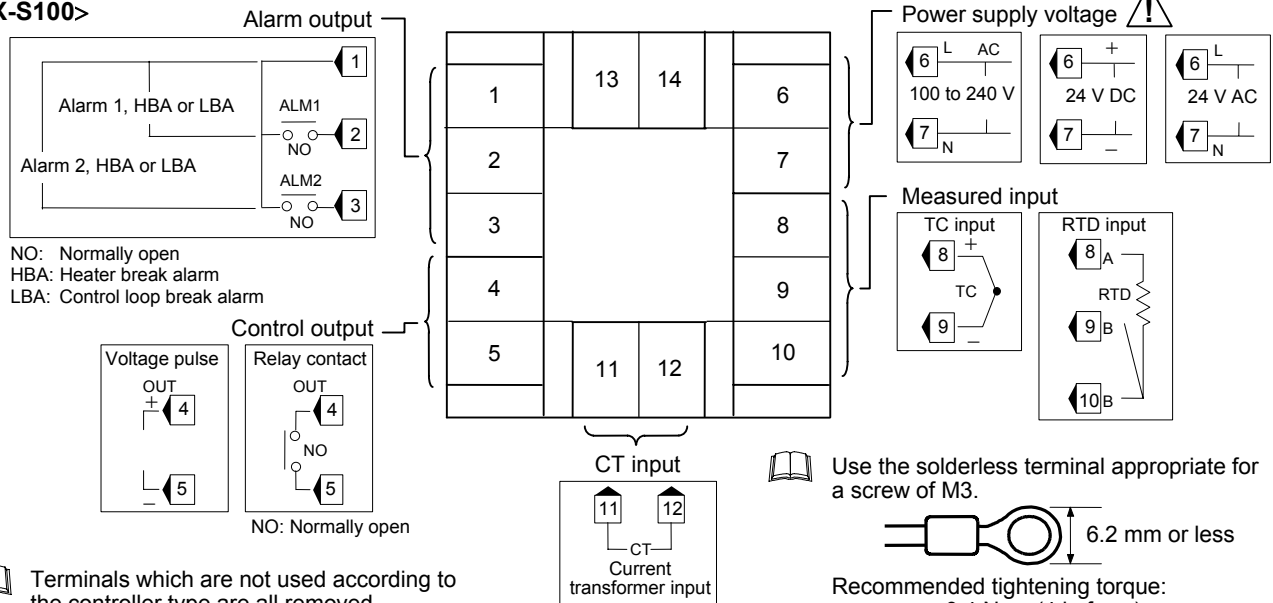

Use the solderless terminal appropriate for a screw of M3.

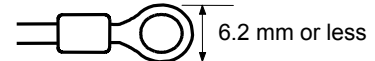

Recommended tightening torque:
0.4 N·m (4 kgf·cm)

Maximum allowance tightening torque:
0.7 N·m (7 kgf·cm)

● Control output

Relay contact output: 250 V AC, 3A (Resistive load), 1a contact
Electrical life: 300,000 times or more (Rated load)

Voltage pulse output: 0/12 V DC (Load resistance 600 Ω or more)

● Alarm output

Relay contact output: 250 V AC, 1A (Resistive load), 1a contact
Electrical life: 50,000 times or more (Rated load)

● Heater break alarm (HBA)

Current transformer (CT) input:
Number of inputs: 1 point
CT type: CTL-6-P-N or CTL-12-S56-10-N (Sold separately)

Input range: CTL-6-P-N: 0 to 30 A
 CTL-12-S56-10L-N: 0 to 100 A

Input rating: Maximum current rating: 120 mA
 Input impedance: 2.5 Ω

● Power

Power supply voltage: 90 to 264 V AC
 [Including power supply voltage variation],
 50/60 Hz, (Rating 100 to 240 V AC)
 21.6 to 26.4 V AC
 [Including power supply voltage variation],
 50/60 Hz, (Rating 24 V AC)
 21.6 to 26.4 V DC
 [Including power supply voltage variation]
 (Rating 24 V DC)

Power consumption: 6 VA max. (at 100 V AC)
 9 VA max. (at 240 V AC)
 6 VA max. (at 24 V AC)
 145 mA max. (at 24 V DC)

<REX-S400/REX-S900>

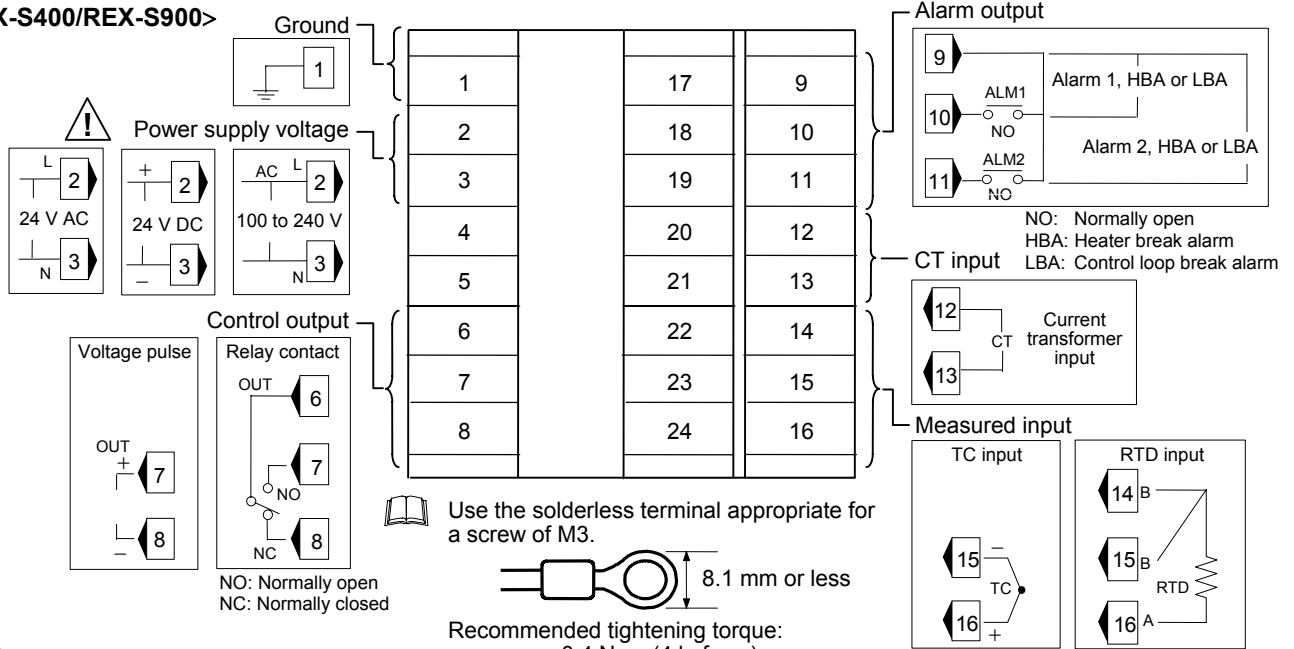

Use the solderless terminal appropriate for a screw of M3.



Recommended tightening torque: 0.4 N·m (4 kgf·cm)
 Maximum allowance tightening torque: 1.0 N·m (10 kgf·cm)

Terminals which are not used according to the controller type are all removed.

An example of the REX-S900 is described here, the same wiring example fig. applies to REX-S400 (Terminal Nos. 17 to 24 are not provided for REX-S400).

● Control output

Relay contact output: 250 V AC, 3A (Resistive load), 1a contact
 Electrical life: 300,000 times or more (Rated load)
 Voltage pulse output: 0/12 V DC (Load resistance 600 Ω or more)

● Alarm output

Relay contact output: 250 V AC, 1A (Resistive load), 1a contact
 Electrical life: 50,000 times or more (Rated load)

● Heater break alarm (HBA)

Current transformer (CT) input:
 Number of inputs: 1 point
 CT type: CTL-6-P-N or CTL-12-S56-10-N (Sold separately)
 Input range: CTL-6-P-N: 0 to 30 A
 CTL-12-S56-10L-N: 0 to 100 A
 Input rating: Maximum current rating: 120 mA
 Input impedance: 2.5 Ω

● Power

Power supply voltage: 90 to 264 V AC
 [Including power supply voltage variation], 50/60 Hz, (Rating 100 to 240 V AC)
 21.6 to 26.4 V AC
 [Including power supply voltage variation], 50/60 Hz, (Rating 24 V AC)
 21.6 to 26.4 V DC
 [Including power supply voltage variation] (Rating 24 V DC)
 Power consumption: 6 VA max. (at 100 V AC)
 9 VA max. (at 240 V AC)
 6 VA max. (at 24 V AC)
 145 mA max. (at 24 V DC)

■ Wiring example

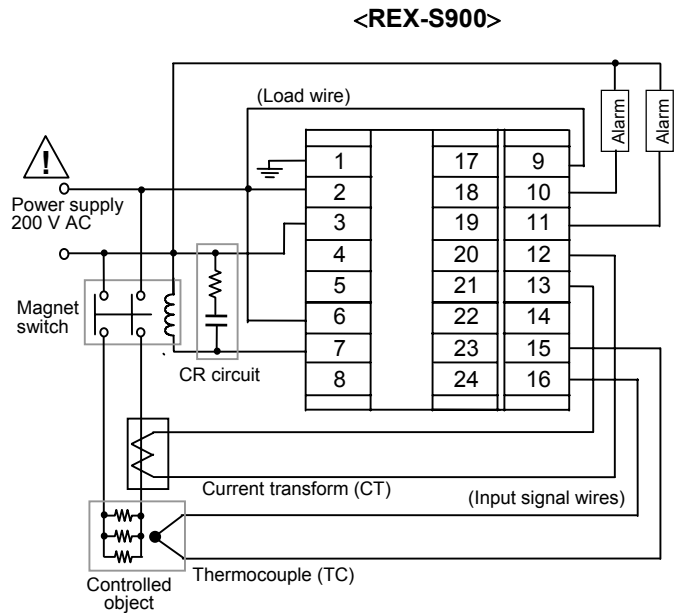
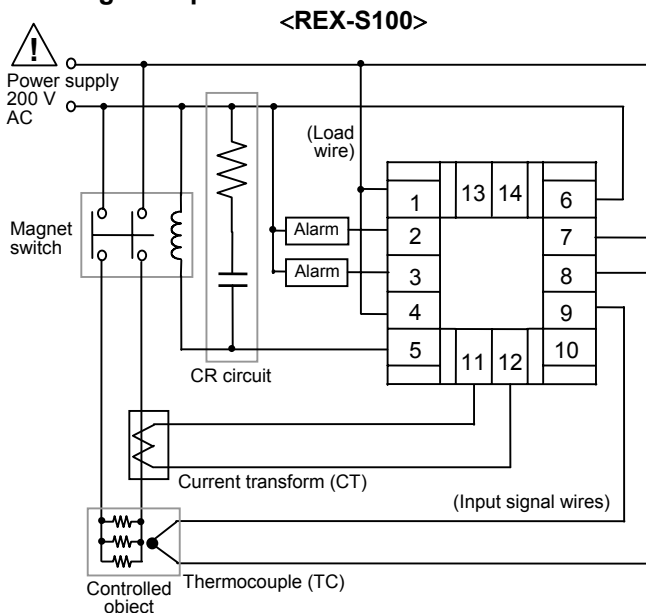

An example of the REX-S900 is described here, the same rear terminals fig. applies to REX-S400 (Terminal Nos. 17 to 24 are not provided for REX-S400).

4. PARTS DESCRIPTION

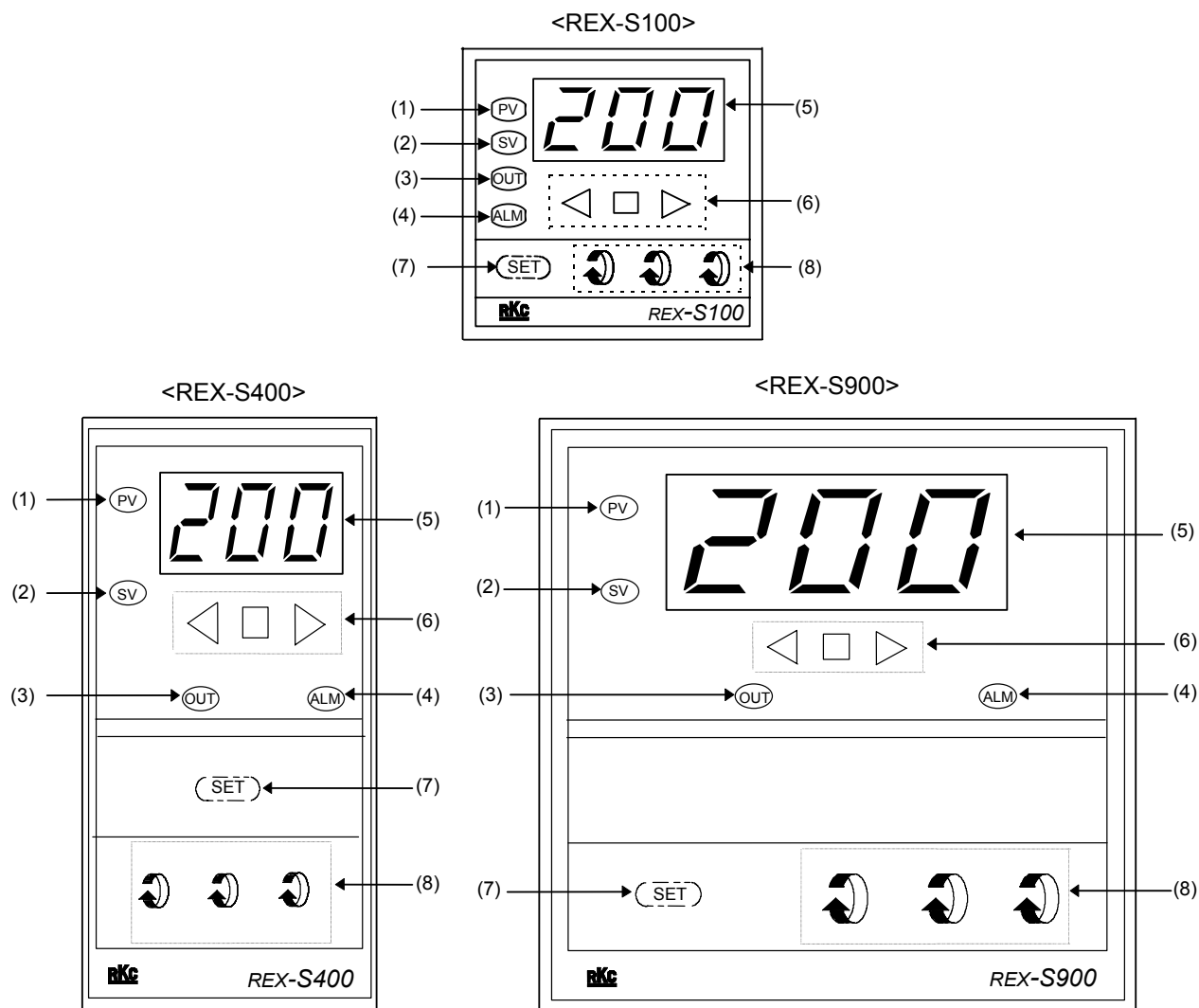

(1) Measured value (PV) display lamp [Green]

- Light up when Measured value (PV) is displayed.

(2) Set value (SV) display lamp [Red]

- Light up when Set value (SV) is displayed.
- Flashes when the Set value (SV) is changed.
- Light up when each parameter is displayed.

(3) Control output lamp [Green]

- Light up when Control output is turned ON.

(4) Alarm (ALM) Lamp [Red]

- Lights up when the Alarm (LBA, HBA) is turned ON.

(5) Measured value (PV), Set value (SV) [Red]

- Displays Measured value (PV) or Set value (SV).
- Displays a parameter symbol or parameter set value in the Parameter setting mode.

(6) Deviation lamps [Red, green and red]

- The respective LED lights according to the different between the Set value (SV) and Measured value (PV).

(7) SET key

- The Set value (SV) thus changed is entered.
- Can select Measured value (PV) and Set value (SV).
- Can select PV/SV mode and Parameter mode.

(8) Numeric-value change key

- This key is used to select the parameter display and parameter set value.
- Used to change the number of each digit.

5. OPERATION

■ Calling-up procedure of each mode and parameter types

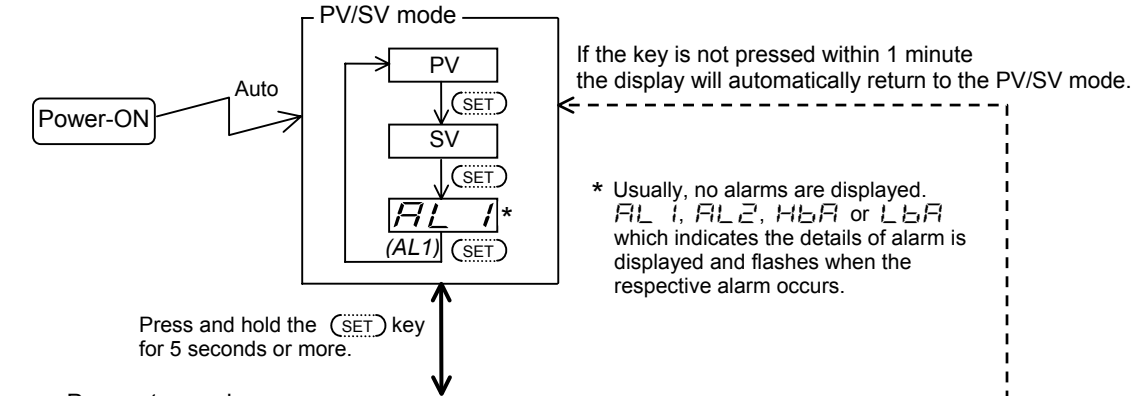

	Name	Description/Setting rang	Factory set value
	Current transformer (CT) input value	Display input value from the current transformer (CT).	—
	First alarm (ALM1)	Deviation/process alarm: -199 to +999 °C [°F] Differential gap: 2 °C [°F]	50 °C [°F]
	Second alarm (ALM2)	Deviation/process alarm: -199 to +999 °C [°F] Differential gap: 2 °C [°F]	50 °C [°F]
	Heater break alarm (HBA)	Alarm value is set by referring to input value form the current transformer (CT). Setting range: 0 to 100 A	0 A
	Control loop break alarm (LBA)	Set Control loop break alarm set value. Cannot be set to "0.0". Setting range: 0.1 to 99.9 minutes	8.0 minutes
	LBA deadband (LBD)	Set the area of not outputting LBA. No LBA deadband functions with "0" set. Setting range: 1 to 999 °C [°F] Differential gap: 0.8 °C [°F]	0 °C [°F]
	Autotuning (AT)	0: Autotuning end or stop 1: Autotuning start	0
	Proportional band (P)	ON/OFF action with P set to "0". Setting range: 1 to Input span	30 °C [°F]
	Integral time (I)	Eliminates offset occurring control is performed. I action turns OFF with I set to "0." Setting range: 1 to 999 seconds	240 seconds
	Derivative time (D)	Prevents ripples by predicting output change thereby improving control stability. D action turns OFF with D set to "0." Setting range: 1 to 999 seconds	60 seconds
	Anti-reset windup (ARW)	Prevents overshoot and/or undershoot caused by integral action. Setting range: 1 to 100 % of Proportional band	100 %
	Proportional cycle (T)	Set control output cycle. Setting range: 1 to 100 seconds	Relay contact output: 20 seconds Voltage pulse output: 2 seconds
	Set data lock (LCK)	0: No set data locked 1: Set data locked	0

Some parameter symbols may not be displayed depending on the specification.

■ Parameter setting procedure

Setting Set value (SV)

When Set value (SV) of 200 °C is changed to 210 °C.

(1) Set to the SV mode

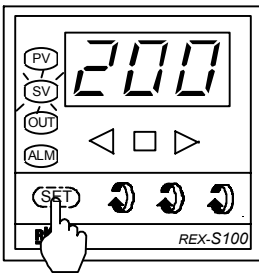

Press the (SET) key enter the SV mode.

(2) Set to SV changing mode

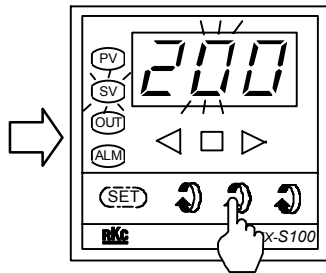

Press the key corresponding to the digit to be set (The set digit brightly lights.)

(3) Numeric-value change

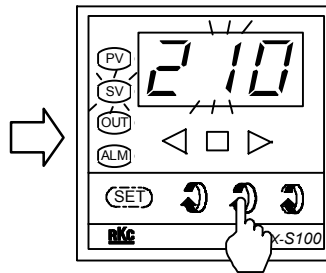

Keep pressing the key corresponding to the digit to be set until the desired number is displayed.

(4) Set value entry

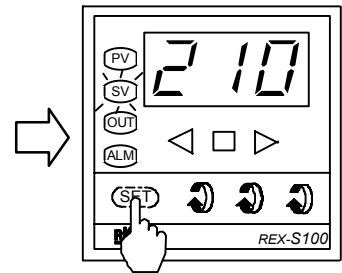

After finishing the setting, press the (SET) key

Setting parameters other than Set value

In the PV/SV mode

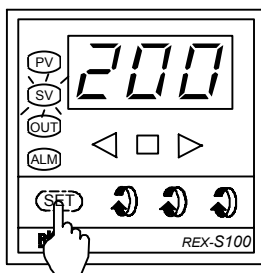

5 seconds or more

In the Parameter mode

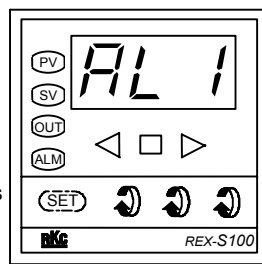

- (1) Press and hold the (SET) key for 5 seconds or more to set controller to the Parameter mode.
- (2) Press the (SET) key by the required number of times until the parameter symbol to be set is displayed.
- (3) The setting procedures are the same as those of example (2) to (4) in the above **Setting Set value (SV)**. (Pressing the (SET) key after the setting is finished in the parameters).

When no parameter setting is required, return the controller to the PV/SV mode.

Key operational cautions

- To store a new value for the parameter, always press the (SET) key.
- After a new value is displayed on the display by using key, if no key operation is performed within 1 minute without pressing (SET) key, this controller returns to the PV/SV mode status and the set value will not be changed.
- When the controller is not set to the SV changing mode (the Set value(SV) does not light brightly or dimly even with the (SET) key pressed) or each value dose not light brightly or dimly even with the controller moved to the Parameter setting mode, set data lock is activated. In this case, change the "LCK" parameter set value to "0."

■ Displaying on deviation lamps

The deviation lamps (◁ □ ▷) lights as follows.

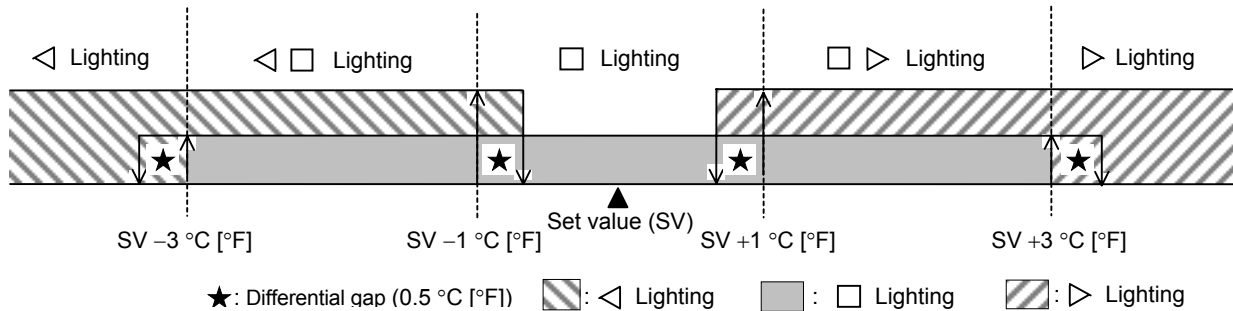

Display during Autotuning: The deviation LED flashes as follows during Autotuning.

■ Set data locking procedure

This controller is provided with a set data locking function which disables each set value change by the front key and also the Autotuning function. Use this function for malfunction prevention.

- (1) Press and hold the (SET) key for 5 seconds or more to set controller to the Parameter mode.
- (2) Press the (SET) key by the required number of times to show "LLL" on the display unit.
- (3) Press the () keys to set the number in the table at right. Thus the set data lock state can be selected.

0	No set data locked.(All parameters changeable)
1	Set data locked.(All parameters not changeable)

CAUTION

- Do not set to numeric values other than 0 and 1, as it may cause a malfunction.
- Checking each set value is possible during data lock.

■ Caution for operation

- Do not use the Autotuning function in a control system where hunting causes trouble. In this case, set each PID constant appropriate to the controlled object.
- Connect the input signal wiring, and then turn ON the power. If the input signal wiring opens, the controller judges that input is disconnected to cause the upscale of measured-value display.
- No influence is exerted upon the controller for power failure of 20 ms. or less. For power failure of 20 ms or more, the controller performs the same operation as that at the time of power-ON after power recovery.
- When the Set value (SV) is changed during progress in the Autotuning function, suspend the Autotuning to perform PID control using the values before Autotuning start.
- When the Autotuning function is suspended halfway, no values of PID and control loop break alarm are changed. (The value before Autotuning function start is maintained.)

■ Error display

● Self-diagnostic error

Display	Description	Solution
Err	RAM error Incorrect set data write, etc.	Please contact RKC sales office or the agent.

● Display when input error occurs

Display	Description	Solution
000 [Flashing]	Over-scale PV is above the high input display range limit.	<div style="text-align: center;">  WARNING </div> <p>In order to prevent electric shock, prior to replacing the sensor, always turn OFF the power.</p>
UUU [Flashing]	Underscale PV is below the low input display range limit.	

The first edition: SEP. 1994
The sixth edition: OCT. 2010 [IMQ00]